

Chamber®



4-SHELF INDUSTRIAL BOLTLESS SHELVING

MODEL NO: CS4600BO & CS41000BO

PART NO: SEE TABLE PAGE 2

ASSEMBLY INSTRUCTIONS



GC0815

INTRODUCTION

Thank you for purchasing this CLARKE Shelving Unit.

Before attempting to use this product, please read this manual thoroughly and follow the instructions carefully. In doing so you will ensure the safety of yourself and that of others around you, and you can look forward to your purchase giving you long and satisfactory service.

SCOPE

These instructions cover the following models

Description	Model	Part Number
4-Shelf 600kg Boltless Shelving (Blue/orange)	CS4600BO	6600728
4-Shelf 1000kg Boltless Shelving (Blue/orange)	CS41000BO	6600730

SPECIFICATIONS

Model	Dimension (W x D x H)	Weight (Empty)	Load per shelf (evenly distributed)
4-Shelf 600kg Shelving	2000 x 600 x 2000 mm	71.8 kg	600 kg
4-Shelf 1000kg Shelving	2000 x 800 x 1800 mm	72.3 kg	1000 kg

INVENTORY

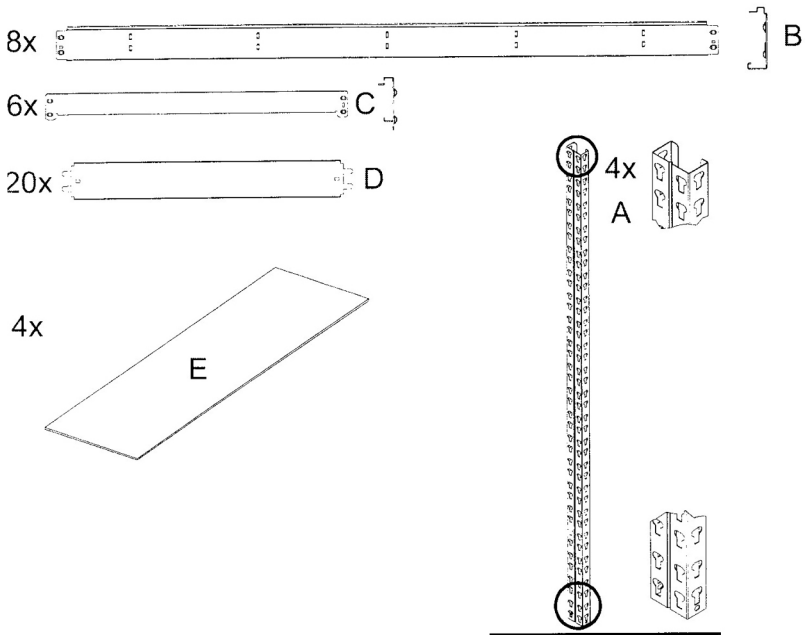

No	Description	Quantity
A	Post	4
B	Long Beam	8
C	Short Beam	6
D	Support Beam	20
E	Shelf	4
F	Foot (fitted)	4

ASSEMBLY INSTRUCTIONS

1. Assemble on a strong, level surface. Avoid assembly on a domestic carpet.
2. Use a cloth or softwood block to protect the surface finish of the product when using a mallet. Strike the flat surface of each beam to prevent damage to the beam.
3. Always ensure that the rivets sit at the bottom of the keyhole slots.
4. It is recommended that the assembly should be done by two persons.
5. Always wear gloves when assembling these units.
6. The shelving unit is not recommended for outdoor use.

TOOLS REQUIRED

- Rubber mallet or hammer
- Protective cloth/wood block
- Spanners (M5)

ASSEMBLY PROCEDURE

1. Assemble the supporting beams as follows.
2. The tabs of the beams will often enter the slots fully using just firm hand pressure but if they are too tight, you may require a rubber mallet to assist. If so, always use a cloth to protect the product paint finish.
3. Tap gently with the mallet to drive the tabs of the beams fully into the slots in the post. Always strike the edge close to the post.

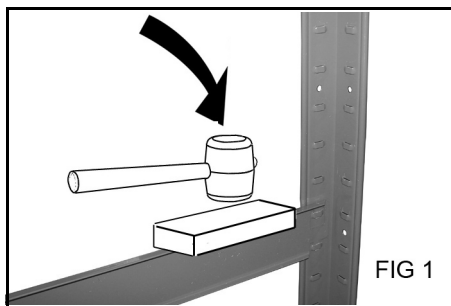

- Use the short beams (C) to connect the front and rear posts together as in Fig 2.

NOTE: The edge with the wider flange should be installed uppermost to support the shelf.

NOTE: Leave a gap of 220mm below the bottom beam and the ground. Leave 100mm gap between the top beam and the top of the posts.

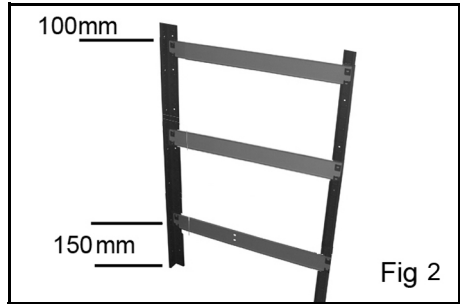

- Repeat this again to create the other end assembly, making sure that the corresponding beams are at the same height as in Fig 3.
- Join the two end assemblies together with the long beams (B) as in Fig 3.
 - The beams should be spaced equally with a gap of 500mm between each one and the top beam will be level with the top of the posts.



- Connect the support beams (D) to the long beams (B) by bending the flexible tabs to 90 degrees and slotting them into place as shown in Fig 4. Finally bend the tabs back to 180 degrees to lock in place.

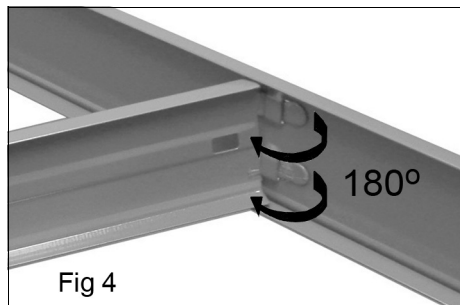

8. Lay the shelf panels (E) into position.

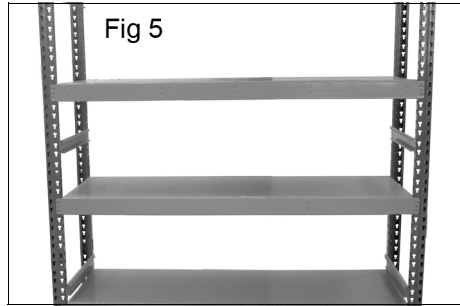

We recommend that the racking be secured to an adjacent wall using typical wall insert plugs and screws (not supplied) aligned with the assembly slots in the posts.

GENERAL SAFETY RULES

1. Always maintain equipment in good condition for the best/safest performance.
2. Never exceed the maximum load for these shelving units as stated in the specification.
3. Never use these units if they are damaged.
4. Always load small, stable items on the top shelves, heavier and bulky items should be stored on the lower shelves.
5. Always distribute heavy loads evenly across the shelves.

Please keep these instructions in a safe place for future reference.

ENVIRONMENTAL PROTECTION

Do not dispose of old products or damaged parts with general household waste. All tools, accessories and packaging no longer required should be sorted, taken to a recycling centre and disposed of appropriately.

GUARANTEE

This product is guaranteed against faulty manufacture for a period of 12 months from the date of purchase. Please keep your receipt which will be required as proof of purchase.

This guarantee is invalid if the product is found to have been abused or tampered with in any way, or not used for the purpose for which it was intended.

Faulty goods should be returned to their place of purchase, no product can be returned to us without prior permission.

This guarantee does not effect your statutory rights.

A SELECTION FROM THE VAST RANGE OF

Clarke®

QUALITY PRODUCTS

AIR COMPRESSORS

From DIY to industrial, Plus air tools, spray guns and accessories.

GENERATORS

Prime duty or emergency standby for business, home and leisure.

POWER WASHERS

Hot and cold, electric and engine driven - we have what you need

WELDERS

Mig, Arc, Tig and Spot. From DIY to auto/industrial.

METALWORKING

Drills, grinders and saws for DIY and professional use.

WOODWORKING

Saws, sanders, lathes, mortisers and dust extraction.

HYDRAULICS

Cranes, body repair kits, transmission jacks for all types of workshop use.

WATER PUMPS

Submersible, electric and engine driven for DIY, agriculture and industry.

POWER TOOLS

Angle grinders, cordless drill sets, saws and sanders.

STARTERS/CHARGERS

All sizes for car and commercial use.



PARTS & SERVICE: 0208 988 7400

E-mail: Parts@clarkeinternational.com or Service@clarkeinternational.com

SALES: UK 01992 565333 or Export 00 44 (0)1992 565335

Clarke® INTERNATIONAL Hemnall Street, Epping, Essex CM16 4LG
www.clarkeinternational.com